



MATERIAL HANDLING PRODUCTS



One Million Square Feet
of Production Facilities



Bendi[®]

B3/30AC



Bendi®

The Bendi model B3/30AC works in aisles as narrow as 72" (1.8M), has a basic capacity of 3,000 lbs. (1361kg) at 24" (600mm) load center and has lift heights available to 30' (9.14M) – maximizing warehouse space by 50% more than a counterbalanced and 35% more than a reach truck.

STANDARD FEATURES

- Three-Wheel Design, Single Front Wheel Drive
- 9.75" (248mm) Stroke Integral Side Shifter
- 220° Front End Rotation
- Adjustable Seat and Steering Wheel
- DuraSteer™ Front Wheel Hydraulic Steering
- AC Traction and Hydraulic Controllers with Lift Interupt
- Full Diagnostic Interactive Color Display with Battery Discharge Indicator and Hour Meter
- Hydraulic Rear Wheel Brakes
- Safety Seat Switch and Seat Belts
- 40" (1000mm) Tapered Tip Forks - Rear Tow Pin
- Hand Actuated Parking Brake
- Creep Speed Mode Selection Switch
- High Visibility Mast and 36" (914mm) High Backrest
- Mast Tilt 1° Forward and 2° Backward
- 48 Volt Electrical System
- Three Section Hydraulic Control Valve
- Smooth Poly Front Drive Tire and Rubber Rear Tires
- Horn, Key Switch and Hour Meter
- 4-Post Heavy-Duty Adjustable Overhead Guard, Meets ANSI B56.1

OPTIONAL FEATURES

- Non-Standard Fork Lengths
- Dual Overhead Guard-Mounted LED Headlights
- Dual Rear Safety LED Light Bars
- Safety Flashing LED Light
- Backup Alarm - Beeping Tone ("Smart" dB Adjusting)
- Fire Extinguisher - OHG Post Mounted
- Roller / Slide-Out Battery Tray
- Lazer Fork Height Indicator
- Fork Positioner
- Keyless Key Pad On-Off
- Cold Storage Conditioned to -22°F (-30°C)
- Camera with Monitor in Operator's Compartment



Scan the QR Code
to Learn More!

B3/30AC

Electric Multi-Purpose VNA Articulated Forklift Truck VNA forklift that can work indoors and out on paved surfaces

TECHNICAL DATA

MODEL		B3/30AC	
Capacity		lbs/kg	3,000 / 1,361
Load Center		in/mm	24 / 600
Power Source			Battery, electric
Weight with Battery		lbs/kg	12,800 / 5,818
Travel Speed	Loaded	mph/kph	5.5 / 8.9
	Unloaded	mph/kph	6 / 9.7
Lift Speed	Loaded	fpm/mpm	90 / 27.4
	Unloaded	fpm/mpm	110 / 33.5
Lowering Speed	Loaded	fpm/mpm	100 / 30.5
	Unloaded	fpm/mpm	90 / 27.4
Mast Tilt	Fwd / Back	deg	1 / 2
Lost Load Center	a	in/mm	14.2 / 361
Wheelbase	b	in/mm	72.6 / 1,844
Overall Length to Face of Forks	c	in/mm	112.9 / 2,868
Underclearance	d	in/mm	3 / 76
Cab Floor Height	e	in/mm	31 / 787
Seat Height	f	in/mm	51 / 1,295
Overhead Guard Height	g	in/mm	89 / 2,261
Chassis Width	h	in/mm	44.8 / 1,138
Gradeability	Unloaded	%	8
	Loaded	%	5
Hydraulic Motor Rating		kW	12
Drive Motor Rating	Single Front	kW	5.1
Wheel Sizes	Front (1 Each)	in/mm	18x7 / 457x178
	Rear (2 Each)	in/mm	18x7 / 457x178
Traction Control Type	Curtis		AC
Hydraulic Control Type	Curtis		AC
Front Articulation	m	deg	220

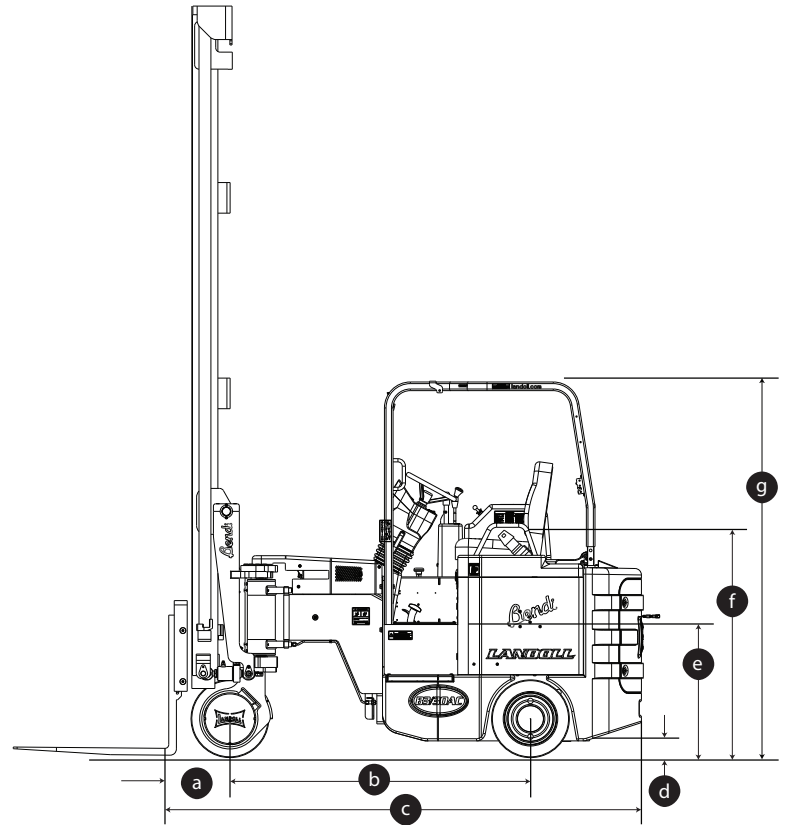
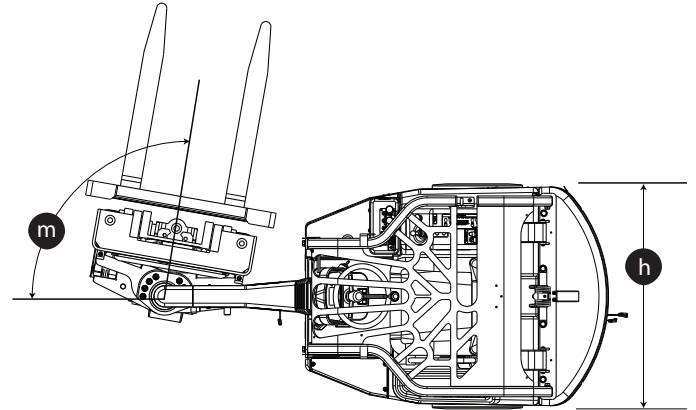

MAST DIMENSIONS

LIFT HEIGHT		LOWERED HEIGHT		FREE LIFT	
Inches	Meters	Inches	Meters	Inches	Meters
156	3.96	92	2.34	56	1.42
204	5.18	108	2.74	72	1.83
222	5.64	118	3.00	82	2.08
250	6.35	133	3.38	97	2.46
288	7.32	147	3.73	111	2.82
312	7.92	155	3.94	119	3.02
360	9.14	174	4.42	138	3.51

AISLE DIMENSIONS

LOAD DEPTH X WIDTH (j x i)	MINIMUM CLEAR AISLE
40" x 48" (1,000 x 1,200mm)	66" (1,676mm)
48" x 40" (1,200 x 1,000mm)	72" (1,828mm)
Minimum Clear Transfer Aisle	121" (3,000mm)

RECOMMENDED BATTERY

BATTERY DESIGNATION: 24-85-17, 48 VOLT, 680 AHC (6 HOUR RATE)

Nominal Size: 27" x 38.5" x 22.625" (69 x 98 x 58cm)

Truck Compartment Size: 27.5" x 38.75" x 23" (70 x 98 x 58cm)

Battery Weight: Min. 2,550 lbs. (1,157kg) - Max. 3,100 lbs. (1,409kg)

Leads are at Position C, 20" (50.8cm) Long, with SB 350 Amp Blue Connector

Landoll continuously improves products. We reserve the right to make any changes in illustrations, specifications, equipment, and prices without prior notice and without changes on previous models.

QUALITY

IS OUR FIRST PRIORITY



Proven Solutions for Storage & Specialty Handling Applications

Family owned and operated since 1963, we make quality our first priority. Our goal is to provide the best solution for your material handling needs. Bendi articulating, Drexel SwingMast® Narrow Aisle and Very Narrow Aisle forklifts provide that solution. Through increased utilization of space, improved productivity, greater flexibility and maximized efficiency. We stay on the edge of modern and innovative technology. We know that for our customers "Quality is Always a Bargain".

Exceptional Customer Support, Parts and Service

Landoll is committed to total customer satisfaction by providing products and services of the highest quality. Aftermarket parts and service is available world-wide through our factory trained dealer network and Landoll's service support department. Our 75,000 sq ft Parts Distribution Center ensures quick and accurate delivery of parts to keep your equipment up and running. Experience for yourself the reason that Landoll Material Handling Products are #1 in customer retention.



MATERIAL HANDLING
landoll.com/mhp

1900 North Street Marysville, KS 66508 · 800-428-5655 · forkliftsales@landoll.com

