

CORNER COLUMN PROTECTORS

Handle-It® Corner Column Protectors are designed as an economical way to protect racking from manually transferred materials. Installation is easy and can be used in many rack protecting applications. Handle It yellow powder-coated paint provides high visibility.

Features & Benefits

- Corner Column Protectors help prevent damage to rack uprights, shelving uprights, partitions, and many other factory and warehouse structures.
- Wrap around the vertical member to be protected, closely fitting, yet protecting, the upright from damage.
- These heavy duty ¼" thick steel protectors are easily mounted by securing to the concrete floor using three ½" diameter wedge anchors (sold separately)
- These heavy steel protectors provide a low cost method of reducing damage to expensive equipment and protecting personnel from falling rack structures hit my moving machinery.
- 24", 18" & 12" standard heights are available with custom heights by special order.
- Corner Column Protectors are painted in safety yellow with a hard powder boat finish for a durable and attractive appearance.



CCP24



(See Next Page for Specs)

Guarantee and Warranty

Personal and professional customer service is offered on all Handle-It Corner Column Protectors. This piece carries a one year limited warranty on all materials and workmanship.

Corner Column Protector Dimensions

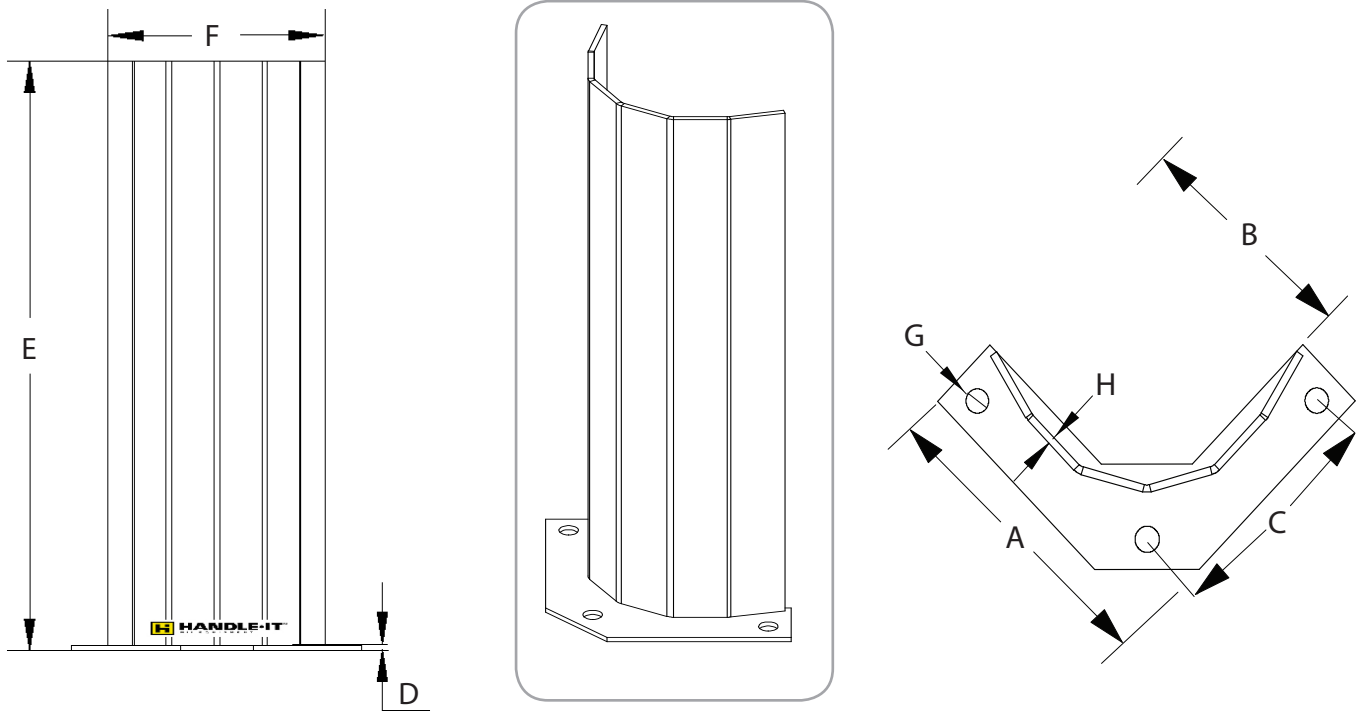

Part	A	B	C	D	E	F	G	H
	Base Plate L & W	Inside Width	Hole to Hole	Base Plate Thickness	Overall Height	Guard Width	Anchor Hole Diameter	Guard Thickness
CCP12	8"	6"	5 ¾"	¼"	12"	6.5"	½"	¼"
CCP18	8"	6"	5 ¾"	¼"	18"	6.5"	½"	¼"
CCP24	8"	6"	5 ¾"	¼"	24"	6.5"	½"	¼"

Corner Column Protector Selection Guide

In order to select the correct size:

- Select desired height (refer to column E)
- Protection equipment should fit as close as possible while still providing an adequate barrier in front of what is being protected

Custom protection is our specialty. If your requirements are not listed in the above specifications, please contact us. Our design team will develop a quick and economical solution for your protection needs.