



ELECTRIC FORKLIFT TRUCKS E18 / E20 / E20C / E20P

3,500 - 4,000 lbs. Capacity

Series 346

- Lowest energy consumption combined with high residual capacity meets the need for maximum versatility in a truck that fits most applications
- Linde Load Control coordinates the dual AC-motor drive axle and electronic control levers to provide stable and precise load handling for any variety of products
- Compact maneuverability through a heavy-duty steer axle (E18/E20) and the Linde exclusive combi steering axle (E20C/E20P) allows the truck to navigate tight spaces
- The standard full-suspension seat with tilt-up armrest and electronic fingertip control levers encourage productive operators with fewer fatigue-related injuries throughout the workday

STANDARD & OPTIONAL EQUIPMENT

STANDARD

- 36-volt or 48-volt chassis
- Dual-pedal travel control
- Cushion tires
- Low-height, lift-out battery exchange
- Standard 80.5" overhead guard
- Three-function hydraulic valve
- Three-function electronic control levers
- Linde Load Control
- Standard tilt (6°F / 5°B)
- Full-suspension vinyl seat with tiltable armrest
- Adjustable padded armrest
- Two front work lights
- Key switch start
- SB350 battery connector
- Emergency power interrupt button
- UL classification, Type E
- Black, non-cinching seat belt
- Maintenance-free wet-disc brakes
- 100% AC traction and lift motors
- Multi-function display indicator
- Tow pin and tie-down cutouts
- Electronic forward horn
- Hydrostatic power steering system
- Adjustable steering column
- Linde Curve Assist speed-control
- Steel entry handle
- Spring-assisted battery cover
- 1000-hour maintenance intervals
- 3-year / 6000-hour (standard warranty)

OPTIONAL

- Single-pedal travel control
- Pneumatic-shaped solid tires (SE)
- Non-marking tires
- Side battery removal with slides/rollers
- Simplex, duplex, triplex, and quad masts
- 38.6" Class II fork carriage
- Integrated / hang-on sideshifter
- Low-profile and drive-in rack overhead guard
- Four-function hydraulic valve
- Four-function electronic control levers
- Bottler's tilt (10°F / 4°B)
- Auxiliary function hydraulic hose reeving
- Quick-disconnect hydraulic fittings
- High comfort textile seat with tiltable armrest
- Tilt angle memory
- Load backrest extension 48"
- LED work lights
- Linde BlueSpot™
- LED rear combination light bars
- Flashing amber strobe light
- Back-up alarm
- Rear handle with horn button
- Fire extinguisher (2.5 lb dry chemical)
- Panoramic rear-view mirror
- Flat rear-view mirror
- High-visibility orange seat belt
- Keyless start switch
- Operator fan
- Cold-storage protection
- UL classification, Type EE

Capacity*

Mast Capacity Table

h1	h3	h2	
80.0	122.0	00.0	Simplex
84.0	129.5	00.0	Simplex
91.5	145.5	00.0	Simplex
77.5	168.0	53.0	Triplex
79.5	174.0	55.0	Triplex
84.0	188.0	59.5	Triplex

E18

1.5" x 4" x 42" Std. Taper Class II Forks**
 Cushion Tires 18 x 7 x 12.13 Drive Tires**
 Class II Sideshifter • Back Tilt Angle = 5°

Capacity (lb) @ 24" Load Center**

Std. Carriage	Integral SS Carriage	Hang-on SS Carriage*
3500	3500	3250
3500	3500	3250
3500	3500	3250
3500	3500	3250
3500	3500	3250
3500	3500	3250

Mast Capacity Table

h1	h3	h2	
80.0	122.0	00.0	Simplex
84.0	129.5	00.0	Simplex
91.5	145.5	00.0	Simplex
77.5	168.0	53.0	Triplex
79.5	174.0	55.0	Triplex
84.0	188.0	59.5	Triplex

E20

1.5" x 4" x 42" Std. Taper Class II Forks**
 Cushion Tires 18 x 7 x 12.13 Drive Tires**
 Class II Sideshifter • Back Tilt Angle = 5°

Capacity (lb) @ 24" Load Center**

Std. Carriage	Integral SS Carriage	Hang-on SS Carriage*
4000	4000	3750
4000	4000	3750
4000	4000	3750
4000	4000	3750
4000	4000	3750
3600	3600	3350

Mast Capacity Table

h1	h3	h2	
80.0	122.0	00.0	Simplex
84.0	129.5	00.0	Simplex
91.5	145.5	00.0	Simplex
77.5	168.0	53.0	Triplex
79.5	174.0	55.0	Triplex
84.0	188.0	59.5	Triplex

E20C / E20P

1.5" x 4" x 42" Std. Taper Class II Forks**
 Cushion Tires 18 x 7 x 12.13 Drive Tires**
 Class II Sideshifter • Back Tilt Angle = 5°

Capacity (lb) @ 24" Load Center**

Std. Carriage	Integral SS Carriage	Hang-on SS Carriage*
4000	4000	3750
4000	4000	3750
4000	4000	3750
4000	4000	3750
4000	4000	3750
3600	3600	3350

* For quick reference only, contact factory for detailed ratings. **Capacity ratings can be affected by changing forks, load center, and/or drive tires.

Technical Data

E18

February 2020

Characteristics	1.1	Manufacturer		Linde	
	1.2	Model designation		E18	
	1.2.1	Chassis configuration		3-Wheel	
	1.3	Power unit: battery, diesel, LP gas		36-Volt Battery	48-Volt Battery
	1.4	Operation: manual, pedestrian, rider standing, rider seated, order picker		Rider seated	
	1.5	Load capacity	<i>Q lb</i>	3500	
	1.6	Load center	<i>c in</i>	24	24
	1.8	Load distance (front overhang)	<i>x in</i>	15.4	15.4
	1.9	Wheelbase	<i>y in</i>	55.9	55.9
Weight	2.1	Service weight with min. battery	<i>lb</i>	8355	8355
	2.2	Axle loading with load, front/rear	<i>lb</i>	10495 / 1361	10495 / 1361
	2.3	Axle loading without load, front/rear	<i>lb</i>	4411 / 3945	4411 / 3945
Wheels & Tires	3.1	Tire type - front/rear: cushion, super elastic, pneumatic		Cushion ¹⁾	Cushion ¹⁾
	3.2	Tire size: front	<i>in</i>	18 x 7 x 12.13	18 x 7 x 12.13
	3.3	Tire size: rear	<i>in</i>	15 x 5 x 11.25	15 x 5 x 11.25
	3.5	Wheels: number front/rear (x = driven)		2x / 2	2x / 2
	3.6	Track width, front	<i>b10 in</i>	35.0	35.0
	3.7	Track width, rear	<i>b11 in</i>	6.8	6.8
	Dimensions	4.1	Mast/fork carriage tilt: forward/back	<i>degrees</i>	6° / 5°
4.2		Height of mast lowered	<i>h1 in</i>	See mast table	See mast table
4.3		Free lift	<i>h2 in</i>	See mast table	See mast table
4.4		Lift	<i>h3 in</i>	See mast table	See mast table
4.5		Height of mast extended	<i>h4 in</i>	See mast table	See mast table
4.7		Height of overhead guard/cab	<i>h6 in</i>	80.5 ²⁾	80.5 ²⁾
4.8		Height of seat	<i>h7 in</i>	38.9	38.9
4.12		Height of tow coupling	<i>h10 in</i>	23.0	23.0
4.19		Overall length with 42" forks	<i>l1 in</i>	121.3	121.3
4.20		Length to fork face	<i>l2 in</i>	79.4	79.4
4.21		Overall width	<i>b1/b2 in</i>	42.0 ⁴⁾	42.0 ⁴⁾
4.22		Fork dimensions	<i>s/e/l in</i>	1.5 x 4.0 x 42.0	1.5 x 4.0 x 42.0
4.23		Fork carriage: class		Class II	Class II
4.24		Width of fork carriage	<i>b3 in</i>	38.6	38.6
4.31		Ground clearance under mast, with load	<i>m1 in</i>	2.9	2.9
4.32		Ground clearance, center of wheelbase	<i>m2 in</i>	3.3	3.3
4.33		Aisle width (must add load length and clearance)	<i>Ast in</i>	80 ³⁾	80 ³⁾
4.35	Turning radius	<i>Wa in</i>	63.9	63.9	
Performance	5.1	Travel speed, with/without load	<i>mph</i>	8.7 / 8.7	10 / 10
	5.2	Lifting speed, with/without load	<i>fpm</i>	59 / 89	60 / 102
	5.3	Lowering speed, with/without load	<i>fpm</i>	96 / 78	96 / 78
	5.6	Maximum tractive force, with/without load (5 min. rating)	<i>lbs</i>	2450 / 2450	2200 / 2200
	5.7	Climbing ability, with/without load	<i>%</i>	16 / 23	16 / 23
	5.10	Service brake		Wet disc	Wet disc
Drive	6.1	Drive motor (60 min. rating)	<i>hp</i>	2x 5.4	2x 6.1
	6.2	Lift motor (15% rating)	<i>hp</i>	10.0	13.4
	6.3	Battery voltage	<i>V</i>	36	48
	6.4	Battery compartment dimension (l x w x h; maximum)	<i>in</i>	25.0 x 38.9 x 25.9 ⁵⁾	25.0 x 38.9 x 25.9 ⁵⁾
	6.5	Battery weight (US battery, minimum / maximum)	<i>lb</i>	2155 / 2730	2155 / 2730
Other	8.2	Working pressure for attachments	<i>psi</i>	2465	2465
	8.3	Oil flow for attachments	<i>gpm</i>	8.5	8.5

1) SE tire available

2) Lower OHG available

3) Add length of load plus operating clearance

4) 46" wide with 200/50-10 SE tires

5) Optional battery removal system will reduce compartment height: 23.34 w/battery rollers — 25.40 w/battery slides

Technical Data

E20

February 2020

Characteristics	1.1	Manufacturer	Linde	
	1.2	Model designation	E20	
	1.2.1	Chassis configuration	3-Wheel	
	1.3	Power unit: battery, diesel, LP gas	36-Volt Battery	48-Volt Battery
	1.4	Operation: manual, pedestrian, rider standing, rider seated, order picker	Rider seated	
	1.5	Load capacity	<i>Q lb</i>	4000
	1.6	Load center	<i>c in</i>	24
	1.8	Load distance (front overhang)	<i>x in</i>	15.4
	1.9	Wheelbase	<i>y in</i>	55.9
Weight	2.1	Service weight with min. battery	<i>lb</i>	8796
	2.2	Axle loading with load, front/rear	<i>lb</i>	11366 / 1430
	2.3	Axle loading without load, front/rear	<i>lb</i>	4412 / 4384
Wheels & Tires	3.1	Tire type - front/rear: cushion, super elastic, pneumatic	Cushion ¹⁾	
	3.2	Tire size: front	<i>in</i>	18 x 7 x 12.13
	3.3	Tire size: rear	<i>in</i>	15 x 5 x 11.25 ²⁾
	3.5	Wheels: number front/rear (x = driven)	2x / 2	
	3.6	Track width, front	<i>b10 in</i>	35.0
	3.7	Track width, rear	<i>b11 in</i>	6.8
Dimensions	4.1	Mast/fork carriage tilt: forward/back	<i>degrees</i>	6° / 5°
	4.2	Height of mast lowered	<i>h1 in</i>	See mast table
	4.3	Free lift	<i>h2 in</i>	See mast table
	4.4	Lift	<i>h3 in</i>	See mast table
	4.5	Height of mast extended	<i>h4 in</i>	See mast table
	4.7	Height of overhead guard/cab	<i>h6 in</i>	80.5 ²⁾
	4.8	Height of seat	<i>h7 in</i>	38.9
	4.12	Height of tow coupling	<i>h10 in</i>	23.0
	4.19	Overall length with 42" forks	<i>l1 in</i>	121.3
	4.20	Length to fork face	<i>l2 in</i>	79.4
	4.21	Overall width	<i>b1/b2 in</i>	42.0 ⁴⁾
	4.22	Fork dimensions	<i>s/e/l in</i>	1.5 x 4.0 x 42.0
	4.23	Fork carriage: class	Class II	
	4.24	Width of fork carriage	<i>b3 in</i>	38.6
	4.31	Ground clearance under mast, with load	<i>m1 in</i>	2.9
	4.32	Ground clearance, center of wheelbase	<i>m2 in</i>	3.3
	4.33	Aisle width (must add load length and clearance)	<i>Ast in</i>	80 ³⁾
4.35	Turning radius	<i>Wa in</i>	63.9	
Performance	5.1	Travel speed, with/without load	<i>mph</i>	8.7 / 8.7
	5.2	Lifting speed, with/without load	<i>fpm</i>	59 / 89
	5.3	Lowering speed, with/without load	<i>fpm</i>	96 / 78
	5.6	Maximum tractive force, with/without load (5 min. rating)	<i>lbs</i>	2450 / 2450
	5.7	Climbing ability, with/without load	<i>%</i>	14 / 22
	5.10	Service brake	Wet disc	
Drive	6.1	Drive motor (60 min. rating)	<i>hp</i>	2x 5.4
	6.2	Lift motor (15% rating)	<i>hp</i>	10.0
	6.3	Battery voltage	<i>V</i>	36
	6.4	Battery compartment dimension (l x w x h; maximum)	<i>in</i>	25.0 x 38.9 x 25.9 ⁵⁾
	6.5	Battery weight (US battery, minimum / maximum)	<i>lb</i>	2155 / 2730
Other	8.2	Working pressure for attachments	<i>psi</i>	2465
	8.3	Oil flow for attachments	<i>gpm</i>	8.5

1) SE tire available

2) Lower OHG available

3) Add length of load plus operating clearance

4) 46" wide with 200/50-10 SE tires

5) Optional battery removal system will reduce compartment height: 23.34 w/battery rollers — 25.40 w/battery slides

Technical Data

E20C / E20P

February 2020

Characteristics	1.1	Manufacturer	Linde	
	1.2	Model designation	E20C / E20P	
	1.2.1	Chassis configuration	4-Wheel	
	1.3	Power unit: battery, diesel, LP gas	36-Volt Battery	48-Volt Battery
	1.4	Operation: manual, pedestrian, rider standing, rider seated, order picker	Rider seated	
	1.5	Load capacity	<i>Q lb</i>	4000
	1.6	Load center	<i>c in</i>	24
	1.8	Load distance (front overhang)	<i>x in</i>	15.4
	1.9	Wheelbase	<i>y in</i>	61.0
Weight	2.1	Service weight with min. battery	<i>lb</i>	8827
	2.2	Axle loading with load, front/rear	<i>lb</i>	11433 / 1393
	2.3	Axle loading without load, front/rear	<i>lb</i>	4729 / 4097
Wheels & Tires	3.1	Tire type - front/rear: cushion, super elastic, pneumatic	Cushion ¹⁾	
	3.2	Tire size: front	<i>in</i>	18 x 7 x 12.13
	3.3	Tire size: rear	<i>in</i>	16 x 6 x 10.5'
	3.5	Wheels: number front/rear (x = driven)	2x / 2	
	3.6	Track width, front	<i>b10 in</i>	35.0
	3.7	Track width, rear	<i>b11 in</i>	31.0
	Dimensions	4.1	Mast/fork carriage tilt: forward/back	<i>degrees</i>
4.2		Height of mast lowered	<i>h1 in</i>	See mast table
4.3		Free lift	<i>h2 in</i>	See mast table
4.4		Lift	<i>h3 in</i>	See mast table
4.5		Height of mast extended	<i>h4 in</i>	See mast table
4.7		Height of overhead guard/cab	<i>h6 in</i>	80.5 ²⁾
4.8		Height of seat	<i>h7 in</i>	38.9
4.12		Height of tow coupling	<i>h10 in</i>	23.0
4.19		Overall length with 42" forks	<i>l1 in</i>	127.9
4.20		Length to fork face	<i>l2 in</i>	85.9
4.21		Overall width	<i>b1/b2 in</i>	42.0 ⁴⁾
4.22		Fork dimensions	<i>s/e/l in</i>	1.5 x 4.0 x 42.0
4.23		Fork carriage: class	Class II	
4.24		Width of fork carriage	<i>b3 in</i>	38.6
4.31		Ground clearance under mast, with load	<i>m1 in</i>	2.9
4.32		Ground clearance, center of wheelbase	<i>m2 in</i>	3.3
4.33		Aisle width (must add load length and clearance)	<i>Ast in</i>	86 ³⁾
4.35	Turning radius	<i>Wa in</i>	70.4	
Performance	5.1	Travel speed, with/without load	<i>mph</i>	8.7 / 8.7
	5.2	Lifting speed, with/without load	<i>fpm</i>	59 / 89
	5.3	Lowering speed, with/without load	<i>fpm</i>	96 / 78
	5.6	Maximum tractive force, with/without load (5 min. rating)	<i>lbs</i>	2450 / 2450
	5.7	Climbing ability, with/without load	<i>%</i>	14 / 22
	5.10	Service brake	Wet disc	
	Drive	6.1	Drive motor (60 min. rating)	<i>hp</i>
6.2		Lift motor (15% rating)	<i>hp</i>	10.0
6.3		Battery voltage	<i>V</i>	36
6.4		Battery compartment dimension (l x w x h; maximum)	<i>in</i>	25.0 x 38.9 x 25.9 ⁵⁾
6.5		Battery weight (US battery, minimum / maximum)	<i>lb</i>	2155 / 2730
Other	8.2	Working pressure for attachments	<i>psi</i>	2465
	8.3	Oil flow for attachments	<i>gpm</i>	8.5

1) SE tire available

2) Lower OHG available

3) Add length of load plus operating clearance

4) 46" wide with 200/50-10 SE tires

5) Optional battery removal system will reduce compartment height: 23.34 w/battery rollers — 25.40 w/battery slides

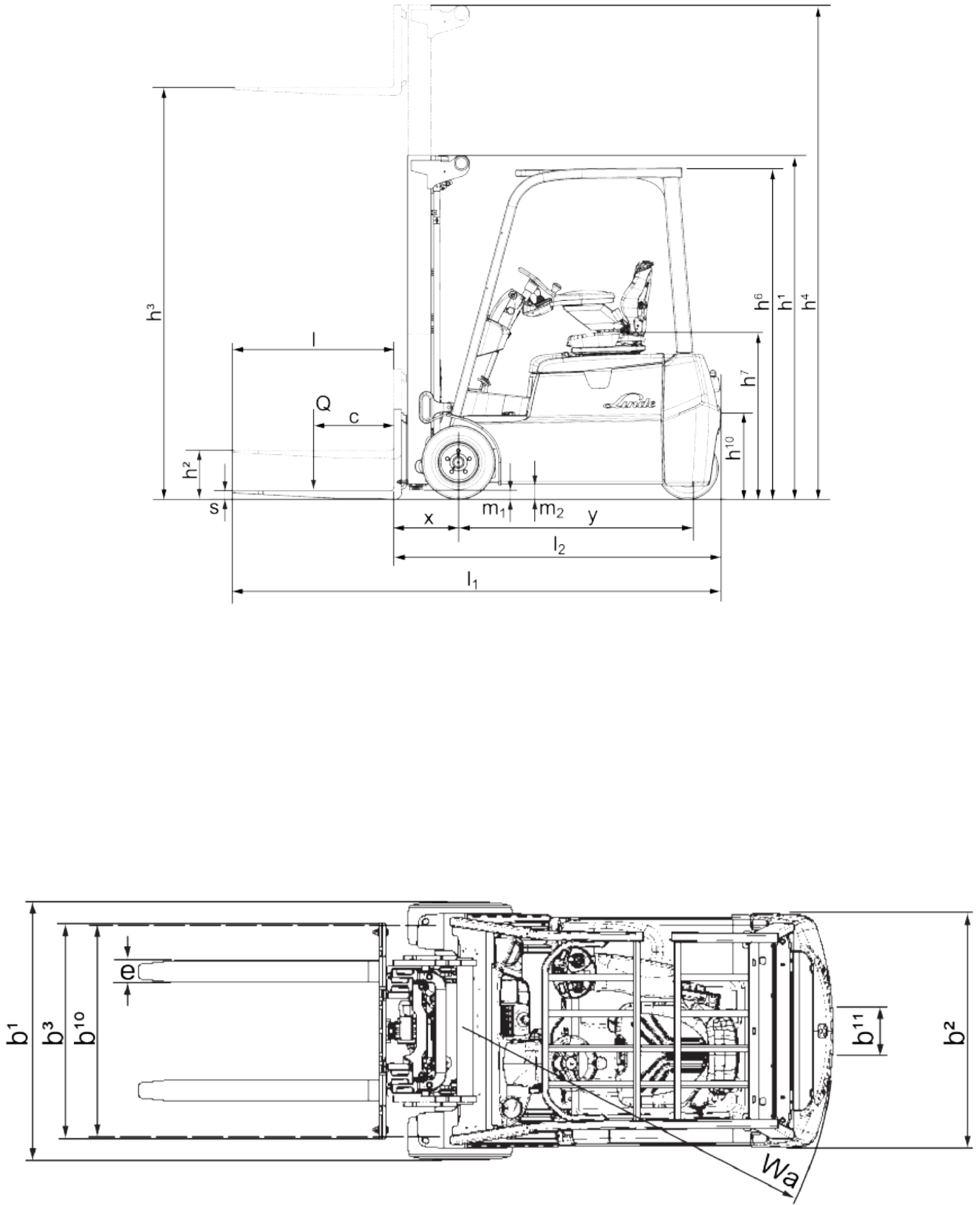

*Refer to Technical Data Chart



ANSI: Standard truck meets all applicable mandatory requirements of ANSI/ISO/BS561 standards for powered industrial trucks.
 NOTE: Performance data may vary due to motor and system efficiency tolerances. The performance depicted represents normal values obtained under typical operating conditions. Metric dimensions are in millimeters unless otherwise specified. All metric dimensions are not direct equivalents due to rounding data. The descriptions and specifications included on this data sheet were in effect at the time of printing. KION North America Corporation reserves the right to make improvements and changes in specification or design without notice and without incurring obligation. Please check with your authorized Linde dealer for information on possible updates or revisions.

For more information on Linde Material Handling equipment, please contact:

KION North America Corporation
 2450 West 5th North Street, Summerville, SC 29483
 Phone: (843) 875.8000 Truck Sales Fax: (843) 875.8471
 Email: trucksales.na@kiongroup.com
 www.kion-na.com

