

UNICARRIERS[®]

FORKLIFT



Electric Pneumatic Tire Lift Truck

80 Volt AC-Powered
5,000 – 7,000 lb. Capacity



MX2-25 - MX2-35L Series

MX2 Series Applications

Clean power built for the job. Adding to our portfolio of electric lift trucks, UniCarriers Forklift continues to meet customer needs while offering a more impactful power source to high-capacity lift trucks. The MX2 series offers dependable performance, durability, and adaptability, while meeting a zero-emission footprint. Backed by an industry-leading two-year warranty and excellent customer service, the MX2 series is your choice when space is tight. Featuring a sleek and compact design, incredible maneuverability, and intelligent control systems, the MX2 series is ideal for the following industries:

- Wholesale trade (durable and non-durable goods) • Lumber
- Trucking and Warehousing
- Food and Beverage
- General Merchandising
- Steel
- Chemicals, Textiles and Rubber



The Total Electric Pneumatic Solution



NEVER QUIT.

It defines our lift trucks and the company that builds them.

Over the course of a century, the company known as UniCarriers Forklift took shape. As we grew and evolved into a US manufacturer with a global reach in nearly 100 countries worldwide, much has changed, but one thing hasn't: Our mission. UniCarriers Forklift is committed to providing you with the ultimate in reliability, performance, and value.

And that commitment can be seen in the MX2 Series. The right choice when space is tight, their compact design, amazing maneuverability and intelligent control systems make them ideal for efficient handling in containers, trucks, drive-in racking and other cramped, fast-paced environments. They are also built to stand up to harsh, wet, dirty or dusty conditions. Add UniCarriers Forklift's legendary reliability, energy efficiency and durability — and you have the right lift truck to move your products, and your business, forward.



Up Your UpTime

Discover reliability features that cut downtime and keep your business up and running



Comfort Zone

Your drivers and your entire operation will benefit from our comfort & productivity features



Power & Performance

Reliable AC motors and controllers are only the beginning of our performance advantages



Play It Safe

Safety is everybody's business, and these models are all business when it comes to safety



Make It Yours

Already well appointed, the MX2 series can be customized to meet your specific needs



To learn more, and find a dealer near you, visit LogisnextAmericas.com/UniCarriers



Up Your UpTime





Advanced Hydraulic Technologies

Optimizes mast and fork movements for smooth, fast, and safe material handling. Load sensing hydraulics adjust to load weight ensuring precise control of the mast and fork movements. In addition, Passive Sway Control Transfers some of the stresses and forces from the mast to the chassis of the truck allowing for confident control and durability in the mast when raising and lowering loads.



Reduce Downtime with Self-Diagnostics

To maximize uptime and maintain the performance levels of these durable lift trucks, we build easy servicing into their design. Integrated on-board diagnostics provide immediate lift truck status. It's intuitive dialogue display combined with accessible service history reduce troubleshooting time, so the unit is back in operation faster. **Everything is done** through a smart LCD panel. No handset device is needed.



The Brake You Need

Sealed wet disc brakes minimize brake wear and extend timing needed between brake service helping to reduce maintenance costs and total cost of ownership. The automatic parking brake activates without the need for traditional pedals, levers, or buttons.



Simplified Battery Maintenance & Replacement

Long-lasting battery enhances performance by minimizing the need for frequent charging or changes. Quick-connect access permits fast charging when necessary.

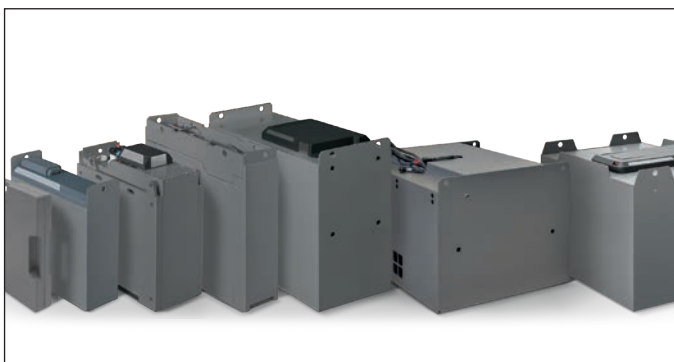

Benefits of Moving to Lithium-Ion Technology

- Fast charging throughout the course of the shift during breaks allows the truck to stay charged when customers need it.
- Li-Ion Batteries are smart power solutions designed to communicate directly with the truck, resulting in increased efficiency and output.
- The Li-Ion solution is completely maintenance free, which can help reduce the total overall cost of ownership and the downtime associated with maintaining and caring for traditional lead acid batteries.
- Battery life expectancy of up to 3,000 full cycles (vs. 900 to 1,200 cycles in lead-acid batteries)
- No gas is produced during charging and no acid is contained in the battery as compared with conventional lead-acid batteries



Comfort Zone



Built for maximum operator comfort, the ergonomically-designed MX2 cabin features a quiet work environment. The electric platform limits noise, increases ease of drive and ultimately eliminates CO₂ emissions.



Improved Control and Productivity

Comfortable in all weather conditions with the optional temperature controlled cabin, which quickly heats up for optimal operator comfort. A fan is also available as a cooling option. Sliding windows on each side of the lift truck help weatherproof the cabin and provide excellent visibility.



Ideal Operating Space

Large, ultra-comfortable operating space has been enhanced to meet the needs of drivers of different shapes and sizes for fatigue-free operation. The spacious footwell provides additional comfort to enjoy a natural, ergonomic, foot position. Quickly step and swing into and out of the spacious operator compartment. The full suspension vinyl seat with weight adjustment adds even more comfort.



Excellent Visibility

Thanks to its optimized mast, steering wheel and dashboard, the MX2 series maximizes visibility to load, forks, front and rear wheels for confident operation in tight spaces. Clear informative full-color display is easy to read from any angle (even in direct sunlight). It's ideally positioned for operator reference and doesn't reduce the lift truck's all-round visibility. From there, the inclined and narrow dashboard design allows clear views from all directions.



Convenience at Your Fingertips

Fingertip control armrest is fully adjustable, ergonomically designed, and allows for comfortable hand-positioning, anatomical support during operation, and free movement.



Power & Performance



With the ability to handle heavier loads with less energy consumption, the MX2 series answers the need for a high-performance solution capable of operating in applications where traditional IC lift trucks cannot. All while being more environmentally friendly and cost-effective.



Intuitive Drive System

The Intuitive Drive System smooths start and stop movements, increases agility, and adapts to the speed of the operator's foot movements.

It adapts performance rapidly in reaction to speed of pedal operation and helps ensure that travel movements, starts and stops are smooth. Intelligent curve control smoothly reduces lift truck speed when the lift truck senses that it is cornering. This lessens lateral forces on the operator, truck, and load.

High Efficiency Motors

Advanced technology such as acceleration boost provides additional power to the motor when the system senses speed reduction (e.g., ramps). High-efficiency electric motor delivers instant torque to help maintain productivity and lift truck speed, creating more torque at low speeds and reducing energy consumption.

Compensates for Load Weight

A load-sensing hydraulic system automatically adjusts for weight to maintain precise control of mast and fork movements. (In lift trucks without intelligent hydraulics, lifting and lowering feels very different when the weight of the load is varied.)

Smooth Steer Operations

MX2's all-wheel steering offers good grip, smooth turning, and extremely agile steering aided by the +100 degree rear steer axle that enables side turn without the need for rear movement.

Adjust for Your Needs

Standard pre-set ECO and PRO modes can be selected for the required application, but also the level necessitated by the experience of the operator.

Built to Last

As well as saving money daily with their low energy consumption, our lift trucks are able to help reduce the total cost of ownership through features such as:

- Sealing of components against water and other contaminants
- Use of highly durable materials and designs
- 1,000-hour PM intervals

Lithium-Ion Batteries

Smart power solutions designed to communicate directly with the truck for increased efficiency and results. Maintenance free which reduces total cost of ownership and downtime from traditional lead acid batteries.

Li-Ion batteries are covered by a 6-year, 3,600 cycles with 75% residual capacity guarantee.

Note: Equipping this model (these models) with a power source (e.g., Lithium-Ion, Hydrogen Full cells, etc.) that has not been approved by the factory is considered a modification. Per OSHA 1910.178 and ANSI/ITSDF B56.1, please consult with your factory representative prior to installing any non-OEM power source that has not been previously approved.



Play It Safe



Work environment safety should be on every employer's mind. The MX2 series provides standard features and options that will help employer's configure their forklifts to help minimize specific hazards associated with their unique application needs.



Light Up Your Path.

Standard LED forward and reverse work lights increase awareness and visibility in low light conditions. Optional front and rear lights are available to further illuminate work zones and provide more warning in the truck's moving area.

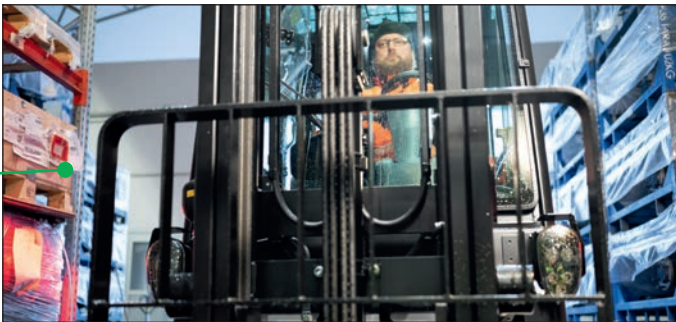

Clearly Better

Excellent visibility thanks to the optimized mast. Combined with the inclined and narrow dashboard, steering wheel, and counterweight design. These features maximize visibility to load, forks, front and rear wheels for safe, confident operation in tight spaces.



Maximize Forklift Control

Electronic differential locks lock out front wheels to increase traction on slippery surfaces – this is activated automatically at small steering angles or manually via an optional front pedal.

In addition, ramp hold automatically activates the parking brake when on a ramp to hold position and prevents rollback when working on a grade and removing foot from accelerator pedal.



Make it Yours

Choose from a variety of options to customize your ride for your application and work environment. If you don't see what you need, contact your authorized UniCarriers Forklift dealer for help.



More Control Options

The optional dual joystick separates auxiliary operating functions and prevents accidental activation of hydraulic functions.

Smart and Durable

It's one of the most intelligent and durable lift truck on the market today. Packed with features, it delivers the maneuverability, power and reliability you expect from UniCarriers Forklift. Modular design simplifies addition or replacement of parts, including overhead guard and cabin options.



Here to Serve You

To help you choose the right model and configuration, and maintain its productivity, we have a dedicated network of dealers. With their specialized knowledge, wide experience and excellent service they will support you in every way to help maximize your profits.

Features	Standard	Option
80V AC Drive System	●	
Preset ECO and PRO performance modes	●	
Lift out battery extraction	●	
Multifunction interactive full color display	●	
Cornering Speed Control	●	
Standard wet disc brakes	●	
TruckTool diagnostics	●	
Operator Presence System (OPS)	●	
Full-suspension vinyl Grammar MSG65 Seat	●	
Integrated LED worklights	●	
Fingertip Control armrest		●
Battery extraction options		●
Additional lights and awareness options		●
PIN code access		●
Automatic tilt centering		●
Panel cabins		●
Side shifters		●
Fork positioners		●
Side battery extraction		●
Multiple tire options		●

DIMENSIONS

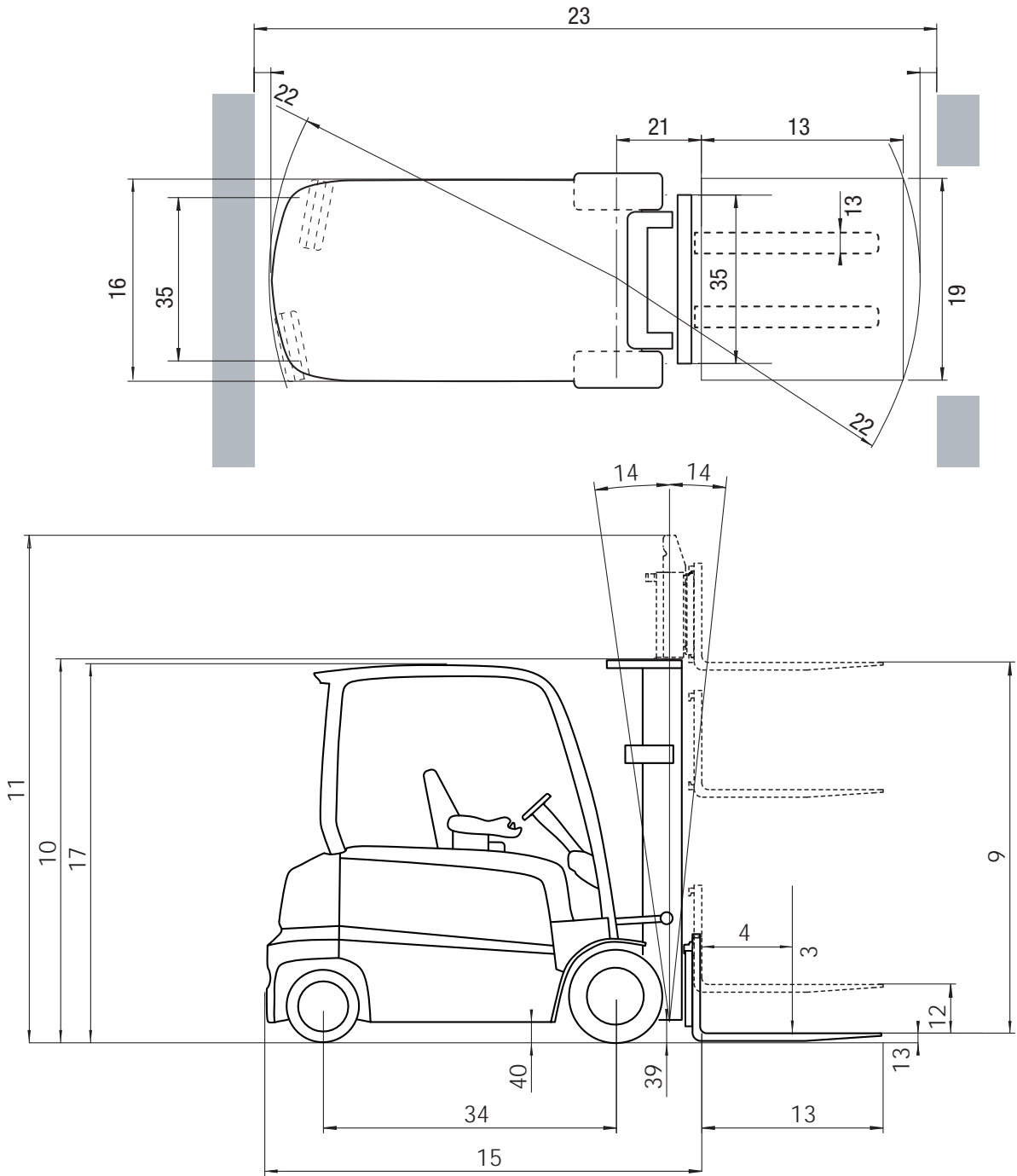

MAIN TRUCK SPECIFICATIONS

CHARACTERISTICS	1	Manufacturer's Name		UniCarriers	UniCarriers	UniCarriers	UniCarriers	UniCarriers	
	2	Model	Model designation	MX2-25	MX2-25L	MX2-30	MX2-30L	MX2-35L	
	3	Rated Load Capacity		5000 (2500)	5000 (2500)	6000 (2875)	6000 (2875)	7000 (3350)	
	4	Load Center	Distance	24 (600)	24 (600)	24 (600)	24 (600)	24 (600)	
	5	Power Type	Electric	Electric/80v	Electric/80v	Electric/80v	Electric/80v	Electric/80v	
	6	Operator Orientation		Seated	Seated	Seated	Seated	Seated	
DIMENSIONS	7	Tire Type	Front & rear	Solid Pneu. SE	Solid Pneu. SE	Solid Pneu. SE	Solid Pneu. SE	Solid Pneu. SE	
	8	Wheels	Number - front/rear (x=driven)	2x/2	2x/2	2x/2	2x/2	2x/2	
	9	Mast	Maximum fork height	in (mm)	171.5 (4355)	171.5 (4355)	170.3 (4325)	170.3 (4325)	171.1 (4345)
	10		Mast lowered (OHL)	in (mm)	84.4 (2145)	84.4 (2145)	85.2 (2165)	85.2 (2165)	90.2 (2291)
	11		Mast extended with LBR	in (mm)	182 (4622)	182 (4622)	182 (4622)	182 (4622)	182 (4622)
	12		Standard freelif	in (mm)	3.9 (100)	3.9 (100)	3.9 (100)	3.9 (100)	3.9 (100)
	13	Forks	Thickness & width & Length	in (mm)	1.6x3.9x42.1 (40x100x1070)	1.6x3.9x42.1 (40x100x1070)	1.6x3.9x42.1 (40x100x1070)	1.6x3.9x42.1 (40x100x1070)	1.6x3.9x42.1 (40x100x1070)
	14	Tilt Angle	Standard mast - fwd/back	degree	6/8	6/8	6/8	6/8	6/8
	15	Overall Dimensions	Length (to face of forks)	in (mm)	94.1 (2389)	99.6 (2530)	95.2 (2417)	100.7 (2558)	100.7 (2558)
	16		Width (standard tires)	in (mm)	46.8 (1190)	46.8 (1190)	46.8 (1190)	46.8 (1190)	46.8 (1190)
	17		Height - top of OHG	in (mm)	88.2 (2240)	88.2 (2240)	88.2 (2240)	88.2 (2240)	88.2 (2240)
	18		Height - top of standard LBR	in (mm)	36 (914)	36 (914)	36 (914)	36 (914)	36 (914)
	19		Width - standard carriage	in (mm)	39.4 (1000)	39.4 (1000)	39.4 (1000)	39.4 (1000)	39.4 (1000)
	20	Grade Clearance	Ramp breakover angle (with/without load)	%	15 / 25	15 / 25	13 / 22	13 / 22	12 / 20
	21	Overhang	Front	in (mm)	18.7 (476)	18.7 (476)	19.8 (504)	19.8 (504)	19.8 (504)
	22	Turning Radius	Minimum outside	in (mm)	75.6 (1920)	81.3 (2064)	75.6 (1920)	81.3 (2064)	81.3 (2064)
	23	Min Right Angle Stack	1000 x 1200 mm pallets, crosswise / 800 x 1200 mm pallets, lengthwise	in (mm)	144.1 (3660)	149.8 (3805)	145.3 (3690)	150.8 (3830)	150.8 (3830)
	PERFORMANCE	24	Speed Maximum	Travel - loaded / unloaded	mph (km/h)	12.4 (20)	12.4 (20)	12.4 (20)	11.1 (18)
		25		Lift - loaded / unloaded	fpm (mm/sec)	98 / 128 (0.5 / 0.65)	98 / 128 (0.5 / 0.65)	89 / 118 (0.45 / 0.6)	89 / 118 (0.45 / 0.6)
26		Lowering - loaded / unloaded		fpm (mm/sec)	108 / 98 (0.55 / 0.5)	108 / 98 (0.55 / 0.5)	98 / 89 (0.5 / 0.45)	98 / 89 (0.5 / 0.45)	
27		Drawbar Pull Maximum	Full load	lb (N)	15800 / 16200	15800 / 16200	15550 / 16050	15550 / 16050	15400 / 16000
28	Gradeability Maximum	Full load (with/without load)	%	23 / 38	23 / 38	20 / 33	20 / 34	18 / 31	
WEIGHT	29	Truck Weight	Empty, min. battery	lb (kg)	10,105 (4,584)	10,445 (4,737)	11,515 (5,220)	11,530 (5,230)	12,465 (5,654)
	30	Weight Distribution	Full load front/rear - min. battery	lb (kg)	13,960 (6332) / 1,740 (789)	13,970 (6336) / 1,905 (864)	16,215 (7355) / 1,935 (878)	16,120 (7313) / 1,850 (839)	18,075 (8186) / 1,995 (904)
	31		No load front/rear - min. battery	lb (kg)	5,055 (2292) / 5,135 (2329)	5,345 (2424) / 5,015 (2275)	5,410 (2454) / 6,130 (2780)	5,670 (2571) / 5,690 (2581)	5,850 (2654) / 6,475 (2937)
CHASSIS & WHEELS	32	Tire Size	Front	in	23 x 9-10	23 x 9-10	23 x 10-12	23 x 10-12	23 x 10-12
	33		Rear	in	18 x 7-8	18 x 7-8	18 x 7-8	18 x 7-8	18 x 7-8
	34	Wheelbase		in (mm)	62.4 (1585)	68.1 (1730)	62.4 (1585)	68.1 (1730)	68.1 (1730)
	35	Tread - Center of Tire	Front / rear (standard tires)	in (mm)	38.8 / 38.2 (985 / 970)	38.8 / 38.2 (985 / 970)	37.4 / 38.2 (950 / 970)	37.4 / 38.2 (950 / 970)	37.4 / 38.2 (950 / 970)
	36	Headroom	SIP to bottom of OHG	in (mm)	39.4 (1000)	39.4 (1000)	39.4 (1000)	39.4 (1000)	39.4 (1000)
	37	Counterweight Height		in (mm)	42.9 (1090)	42.9 (1090)	42.9 (1090)	42.9 (1090)	42.9 (1090)
	38	Step Height		in (mm)	18 (455)	18 (455)	18 (455)	18 (455)	18 (455)
	39	Ground Clearance	Under mast	in (mm)	4.1 (105)	4.1 (105)	4.5 (115)	4.5 (115)	4.5 (115)
	40		Under frame, center of wheelbase	in (mm)	4.8 (122)	4.8 (122)	4.8 (122)	4.8 (122)	4.8 (122)
	41	Service Brake	Type		Hydraulic	Hydraulic	Hydraulic	Hydraulic	Hydraulic
42	Parking Brake	Type		Magnetic	Magnetic	Magnetic	Magnetic	Magnetic	
43	Steering	On-demand		Electric	Electric	Electric	Electric	Electric	
DIN 320A 48V LINE	44	Traction Motor	Type / Rating (1-hour)	kW	AC / 2 x 8 kW	AC / 2 x 8 kW	AC / 2 x 8 kW	AC / 2 x 8 kW	AC / 2 x 8 kW
	45		Control type		AC	AC	AC	AC	AC
46	Pump Motor	Type / Rating (5-minute)	kW	AC / 20.8 kW	AC / 20.8 kW	AC / 25.5 kW	AC / 25.5 kW	AC / 25.5 kW	
BATTERY	47	Battery Compartment Size	W x H - Maximum	in (mm)	40.5 x 30.9 (1,028 x 784)	40.5 x 30.9 (1,028 x 784)	40.5 x 30.9 (1,028 x 784)	40.5 x 30.9 (1,028 x 784)	40.5 x 30.9 (1,028 x 784)
	48		L - Maximum	in (mm)	28.0" (711.2)	33.7 (855)	28.0" (711.2)	33.7 (855)	33.7 (855)
	51	Battery	Type		Lead acid	Lead acid	Lead acid	Lead acid	Lead acid
	52	Capacity	Maximum	AH/5h	620	775	620	775	775
	53	Weight	Minimum / Maximum	lb (kg)	3,262 (1,480) / 3,725 (1,689)	3,905 (1,770) / 4,540 (2060)	3,262 (1,480) / 3,725 (1,689)	3,905 (1,770) / 4,540 (2060)	3,905 (1,770) / 4,540 (2060)
54	Lead Length	Position B	in (mm)	15.7 (400)	15.7 (400)	15.7 (400)	15.7 (400)	15.7 (400)	

Reliability.

It's the defining trait of our company and our lift trucks.



UniCarriers Forklift's roots extend back over 100 years, and over that time, strong, reliable performance has always been the hallmark of our organization, our people and our equipment.

Today, our unrivaled reliability continues to provide UniCarriers Forklift's customers with a competitive edge. And together, we move the merchandise that moves world commerce with greater efficiency, economy and reliability.

When it comes to providing forklifts that make a difference for our customers and theirs...

We Never Quit.

UNICARRIERS[®]
[**FORKLIFT**]

LogisnextAmericas.com/UniCarriers

SB-MX2 05-2024 Printed in U.S.A.

© 2024 Mitsubishi Logisnext Americas Inc. UniCarriers[®] is a registered trademark of Mitsubishi Logisnext Co., Ltd. Mitsubishi Logisnext Americas, Inc. reserves the right to make product changes relating to colors, equipment, specifications or available options without notice. For more information, contact your UniCarriers Forklift representative.

