

TEXTILES



From bobbins to bales or cotton to carpet, Cascade attachments help reduce product damage and increase handling speed.



Reduce product damage while increasing efficiency.



Handling Awkward Loads? Cascade has the Solution.

On average, textile mills handle raw or partially finished product up to 50 times, which makes the equipment used to handle it a very important part of the procedure. Lifting and moving bins and stillages can easily be accomplished with the proper lift truck attachment. From Bale Clamps to Bin Dumpers and Carpet Poles, Cascade has a variety of attachments that improve efficiencies in the production process.





Bale Clamps

Densely packed bales of cotton or wool are transported with ease using a Cascade Bale Clamp. Add 360° revolving motion, in both directions, to truck forks. Perfect for load inverting and dumping loads.



TURNAFORK™

Used in a variety of manufacturing, receiving, warehousing and shipping environments that require both clamp handling and pallet handling. Rotate the arms to the vertical position for clamping, or to the horizontal position to handle most types of conventional pallets. Also used for clamping awkward or difficult loads.



Bar Arm Attachments

Designed primarily for the textile industry, Cascade Bar Arm Attachments are used for handling rolls of cloth material such as towels, linens and denim.

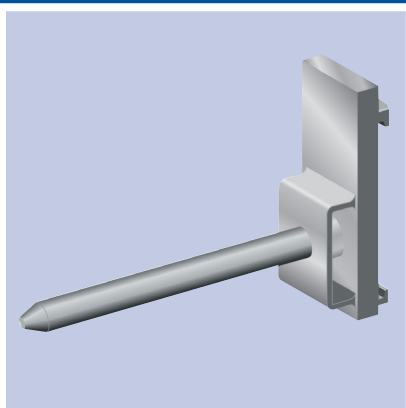

Carpet Poles

For applications that handle carpet rolls or large rolls of fabric. The Carpet Pole is either mounted to a backplate or can hook directly onto the fork to keep load loss to a minimum.



TURNALOAD™

A dual purpose attachment for both clamp and pallet handling. Useful in shipping, receiving and order picking operations requiring both palletless handling of boxes, crates and cartons, as well as palletized loads and bales.



Fork Positioners

Quick and accurate fork positioning without leaving the driver's seat allows for faster load handling and reduced product damage.

Whatever the application, we can handle it.



Weigh Forks

These unique and innovative forks let you weigh your product as you lift it. The wireless display uses Bluetooth® technology enabling you to view and track the weight of individual loads and total weight of multiple loads.



Rotators with Bin Hold Down

Add 360° revolving motion, in both directions, to truck forks. Used in any application where load inverting and dumping loads is necessary.



Stationary Load Inverters

A reliable, economical and efficient means of inverting loads. Allows transfer of product to pallet or slipsheet, freezer spacer removal, damaged pallet exchange or damaged carton replacement. Also provides system for damaged product recovery from bottom of stack.



Multiple Pallet Handlers

Allows driver to use the same lift truck to handle either single or double pallet loads. Spreading the four forks allows handling of two pallets side by side. When brought together, the four forks convert to two forks ready for single pallet handling. Well suited for truck trailer loading and unloading. Also available are Single-Double-Triple Pallet Handlers, Long Forks and High-Capacity models.

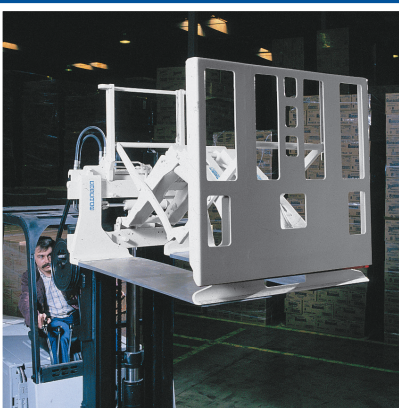

Push/Pulls

Push/Pulls allow you to ship, receive and warehouse unit loads on inexpensive slip sheets rather than pallets. Using slip sheets eliminates the cost of pallet purchase, maintenance, disposal and storage while increasing cube utilization.

Cascade Corporation • PO Box 20187 • Portland, OR 97294-0187 • USA • 800 CASCADE (227.2233) • Tel 503.669.6257 • Fax 800.693.3768 • Fax 503.669.6367
 Cascade Canada Ltd. • 5570 Timberlea Blvd. • Mississauga, Ontario L4W 4M6 • Canada • 800.380.2272 • Tel 905.629.7777 • Fax 905.629.7785