



LPT45

4,500 lb. Capacity Integrated Lithium-ion Pallet Truck

LI-ION



CAPACITY

4,500 lb. at 24" load center.

BATTERY

24V 100Ah Li-ion battery with internal, 120VAC 30A plug-in smart charger.

SPEED

- Travel - 3.7 mph empty / 3.4 mph loaded
- Lift - 4.3 feet/min
- Lowering - 7.7 feet/min

WHEELS

Drive - 9" x 2.95" polyurethane
Load - (2) 3.1" x 3.3" polyurethane
Casters - (2) 2.9" x 1.2" polyurethane

HYDRAULICS

DC pump and chrome plated cylinder provide smooth and efficient lifting.

DRIVE

24 Volt, AC drive motor delivers high torque and efficiency to extend duty cycle.

ELECTRICAL

24V ZAPI travel control provides high performance throughout the entire speed range. Travel speed remains constant relative to throttle position, regardless of load. Separately fused power control circuits, quick disconnect EPD power cut-off and control head mounted hour meter/battery discharge indicator with Bluetooth connectivity via phone app.

OPERATOR CONTROLS

Travel, lift and lower functions are located on the ergonomic control head. All operator controls are accessible without having to lift one's hand from the handle grips. The control head is designed to allow for easy operation with either hand and includes a bellybutton reversing switch, dual butterfly travel controls, horn, battery discharge indicator and key switch. The low-mounted tiller arm offers excellent operator comfort and minimum steering effort.

FORKS

Designed for use with standard 48" pallets and other common skids and containers, the forks can achieve a maximum elevation of over 8", are built for heavy-duty use and come standard with a robust fork entry roller for reliable pallet entry.

BRAKES

Electromagnetic brake provides good stopping power when handle is upright or lowered beyond the operating range.

SERVICEABILITY

Removable covers and modular design of components offer easy maintenance with simple hand tools. Two-piece drive wheel reduces the complexity of tire changes.

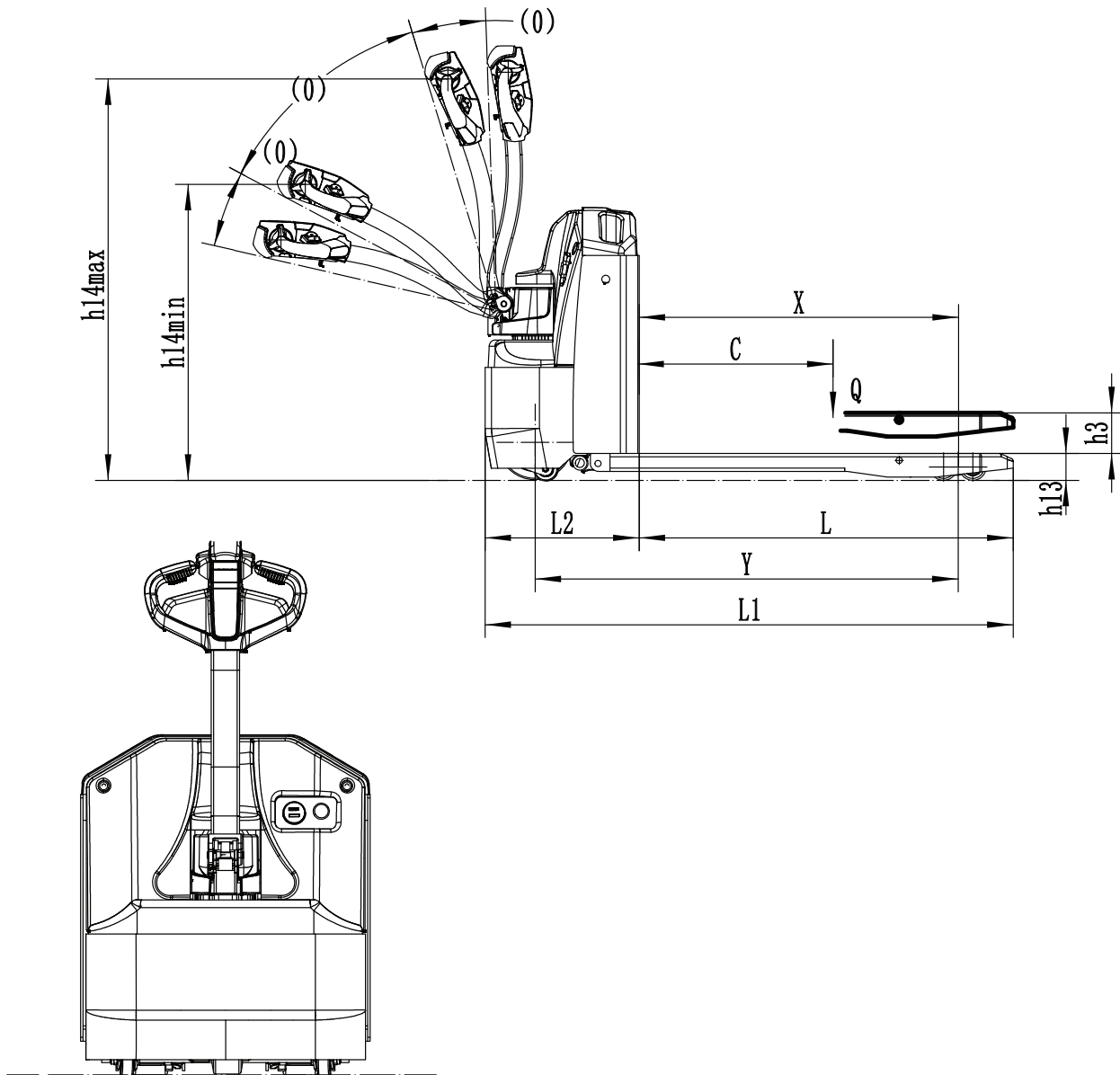

Distinguishing mark	Manufacturer			Big Joe
	Model			LPT45
	Drive			Electric
	Load capacity	Q	lb.	4,500
	Load center distance	c	in.	24
	Load distance, center of drive axle to fork	x	in.	38
	Wheelbase	y	in.	51
Svc weight	Service weight			lb. 705
	Axle loading, laden (front/rear)			lb. 1815 / 3290
	Axle loading, unladen (front/rear)			lb. 562 / 143
Wheels/chassis	Wheel type			Polyurethane
	Wheel size, front			in. 9.06 x 2.95
	Wheel size, rear			in. 3.14 x 3.34
	Additional wheels			in. 2.90 x 1.18
	Wheels, number (front/rear) - x=drive wheels			1x, 2 load
	Tread width, front	b10	in.	19
Tread width, rear	b11	in.	14.5	

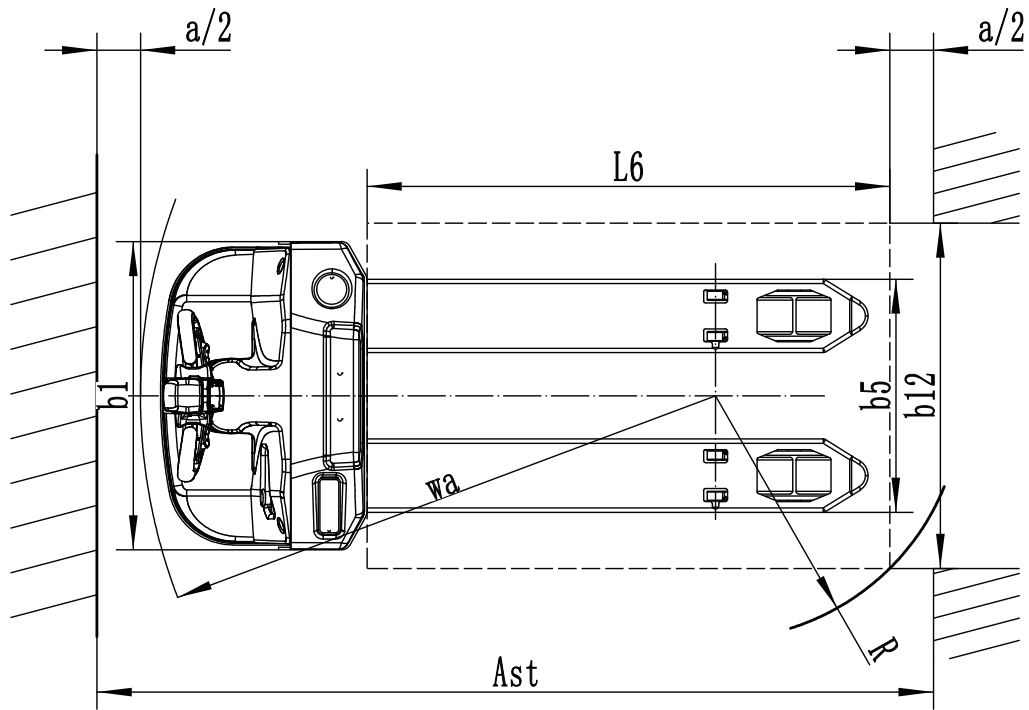

Dimensions	Lift height stroke	$h3$	in.	4.9
	Height of tiller handle in drive position (min / max)	$h14$	in.	35.4 / 48.4
	Lowered height	$h13$	in.	3.2
	Overall length	$l1$	in.	63.7
	Length to face of forks	$l2$	in.	18.5
	Overall width	$b1/b2$	in.	28
	Fork dimensions	$s \times e \times l$	in.	2.1 x 6.7 x 45.2
	Fork spread	$b5$	in.	21.2 / 26.9
	Ground clearance, center of wheelbase	$m2$	in.	1
	Right angle stack (assumes 40" W x 48" D pallet)		in.	74.26 + Clearance
	Turning radius	Wa	in.	51.9
Performance	Travel speed, laden/unladen		mph	3.4 / 3.7
	Lifting speed, laden/unladen		fpm	4.3
	Lowering speed, laden/unladen		fpm	7.7
	Max gradeability, laden/unladen		%	8 / 16
	Service brake			Electromagnetic
Electrical	Drive motor rating S2 60min		kW	1.6
	Lift motor rating at S3 15%		kW	0.8
	Battery voltage / nominal capacity		V/Ah	24 / 100 Li
	Battery weight		lb.	97
Additional	Type of drive control			AC
	Steering design			Mechanical
	Sound pressure level at operator's ear		dB(A)	74
	Charger output current		A	30

STANDARD EQUIPMENT

- UL-recognized 24V 100Ah lithium-ion battery
- 30A, 120VAC internal plug-in smart charger
- Zapi controller
- AC Drive motor
- Drive tire: (1) 9" x 2.95" Polyurethane
- Load wheels: (2) 3.1" x 3.3" Polyurethane
- Casters: (2) 2.9" x 1.2" Polyurethane
- Ergonomic control handle with lift and lower buttons
- Battery discharge indicator
- Belly button reversing switch and horn
- Turtle-mode for narrow space navigation (pinwheeling)
- Ultra-slim design for great maneuverability
- Key switch
- Estimated charging time: 2.7 hours

OPTIONAL EQUIPMENT

- Traction drive tire (Rubber)
- 36" or 48" fork length
- 48" or 60" load backrest
- Freezer/Corrosion package



Freezer/Corrosion Package

- Operational temperatures down to -40°F
- Charging temperature must be above 41°F
- Waterproof tiller head with heater
- Li-ion battery with heating function
- Rubber traction wheel
- Low temperature hydraulic oil
- Magnetic tiller switch
- Anti-corrosion primer, thicker paint, thicker powder coat
- Electromagnetic brake heater
- Waterproof electrical connectors (IP67 Amp seal)
- Corrosion resistant hydraulic hose fittings



Learn more at bigjoeforklifts.com
630-916-2600
sales@bigjoeforklifts.com
749 Little Potato Way, Ste 400 DeForest, WI 53532

Certification

All units are built to be in compliance with ANSI B56.1 and the Occupational Safety & Health Act (OSHA). Big Lift LLC will not assume liability for injuries or damage arising from, or caused by, the removal of any safety devices from their vehicles by user. Because of the Big Lift LLC continuing product improvements, specifications are subject to change without notice.

© Copyright 2024, Big Lift LLC - Printed USA 053024