



ELECTRIC CENTER RIDER PALLET TRUCK ECR 30 / 40

6,000 - 8,000 LBS. Capacity

Series 1102

- Designed for long or short travel distances and low-level order picking
- Power steering reduces steer effort by up to 70% helping to lower operator fatigue
- Large low step platform allows operators to easily navigate the compartment comfortably
- Heavy-duty forks and undercarriage provide greater strength, stability, and longer fork integrity over the life of the truck
- Easy pick system with electronic coasting feature allows for operation on or off the truck

STANDARD & OPTIONAL EQUIPMENT

STANDARD

- AC drive motor
- Manual steering with tilt column
- Regenerative braking
- Operator presence switch
- Rubber, anti-fatigue mat
- Horn / Key switch
- Knee pad
- Lean-on seat
- On-board diagnostics
- Sealed harness connectors
- Multifunction dash display
- UL "E"
- Heavy-duty casters
- Pallet entry rollers

OPTIONAL

- Direct electric steering
- Drive tire and load wheels options
- Battery compartment rollers
- Storage tray
- Shrink wrap holder
- Easy pick system
- Cold storage / corrosion protection
- Travel / back-up alarm
- Travel / back-up flashing lights
- Front work light
- BlueSpot™
- UL "EE" rating
- Keyless On / Off
- Fold-down step for added reach

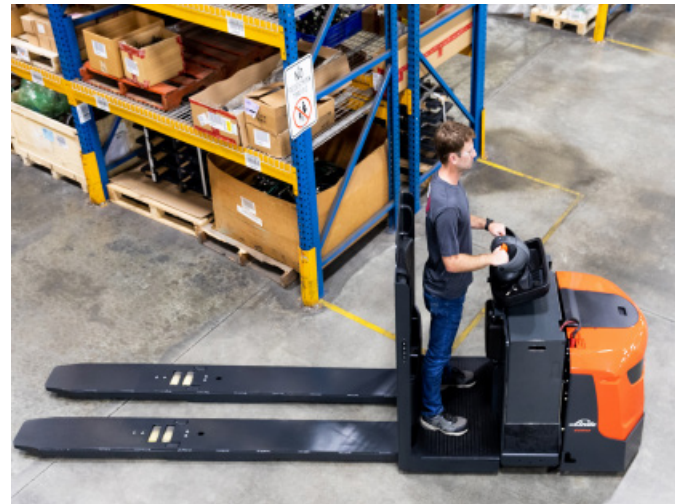



ECR 30 / 40 TECHNICAL DATA

February 2020

Characteristics	1.1	Manufacturer				LINDE			
	1.2	Model designation				ECR30		ECR40	
	1.3	Power unit				Electric		Electric	
	1.4	Operation				Stand-on		Stand-on	
	1.5	Load capacity	Q	lbs	kg	6000	2722	8000	3629
	1.6	Load center	c	in	mm	Fork length / 2		Fork length / 2	
	1.9	Wheelbase	WBR / WBL	in	mm	See chart		See chart	
Weights	2.1	Service weight (w / min. battery)		lbs	kg	3140	1424	3140	1424
	3.1	Tire type, front / rear				Cushion/poly		Poly/poly	
	3.2	Drive tire size, front		in	mm	12 x 5 x 8	305 x 127 x 203	12 x 5 x 8	305 x 127 x 8
	3.3	Load wheel size, rear		in	mm	3.25 x 6.38	83 x 162	3.25 x 6.38	83 x 162
	3.4	Caster wheel dimension		in	mm	4 x 2.5	102 x 64	4 x 2.5	102 x 64
	3.5	Wheels, number front / rear (X=driven)				1x/2		1x/2	
Dimensions	4.19	Overall length	l_4	in	mm	See chart			
	4.2.0	Head length	l_2	in	mm	45	1142	45	1142
	4.21	Overall width	b_1	in	mm	34.6	879	34.6	879
	4.2.2	Fork dimensions	w_s, l_s, w_2	in	mm	See chart			
	4.3.3	Aisle width*	Ast	in	mm	114	2896	114	2896
	4.35	Outer turning radius	TRR / TRL	in	mm	See chart			
	4.4	Lift	h_3	in	mm	6.0	152	6.0	152
	4.4.1	Lift from floor		in	mm	9.25	235	9.25	235
	4.7	Platform height	h_7	in	mm	5.1	130	5.1	130
Performance	5.1	Travel speed, with load		mph	km/h	7.5	9.7	7.5	9.7
	5.1.1	Travel speed, without load		mph	km/h	12.1	15.6	12.1	15.6
	5.8	Maximum gradeability with load		%		11		9.5	
	5.8.1	Maximum gradeability without load		%		15		15	
	5.9	Acceleration time with load		s		6.1		6.5	
	5.9.1	Acceleration time without load		s		5		5	
	5.10	Service brake				Electric			
Drive	6.1	Drive motor		hp	kW	5.4	4.0	5.4	4.0
	6.2	Lift motor		hp	kW	2.95	2.2	2.95	2.2
	6.4	Battery voltage	V			24			
	8.1	Travel control				AC			

NOTICE: Products are subject to change without notice. Our products are continuously being improved, all conditions, terms, and specifications are subject to change at any time.

*NOTICE: Aisle width calculated with 48" forks and a 40" wide pallet. Add 6-8" for operating clearance.

BATTERY SPECIFICATIONS WITHOUT ROLLERS AND CONVENIENCE TRAY								
Voltage	Position	Lead Length	Connector	Compartment Size	Battery Size			Min. / Max Weight Required
					"x" (width)	"y" (length)	"z" (height)	
				X x Y x Z (in)	in.	in.	in.	lbs. (kg)
24	B	21"	SB 175 Red	31.4" x 13.4" x 31.4"	31.2"	13.2"	31.1"	900-1500 (408-680)

NOTICE: See battery selection guide for more information when ordering rollers or convenience tray

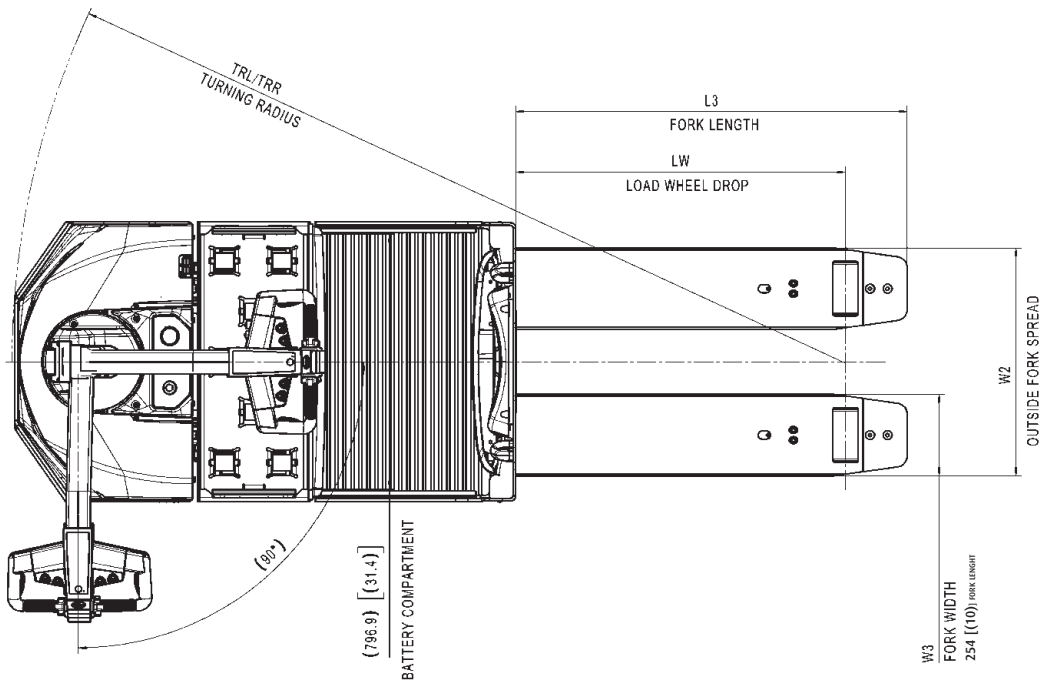
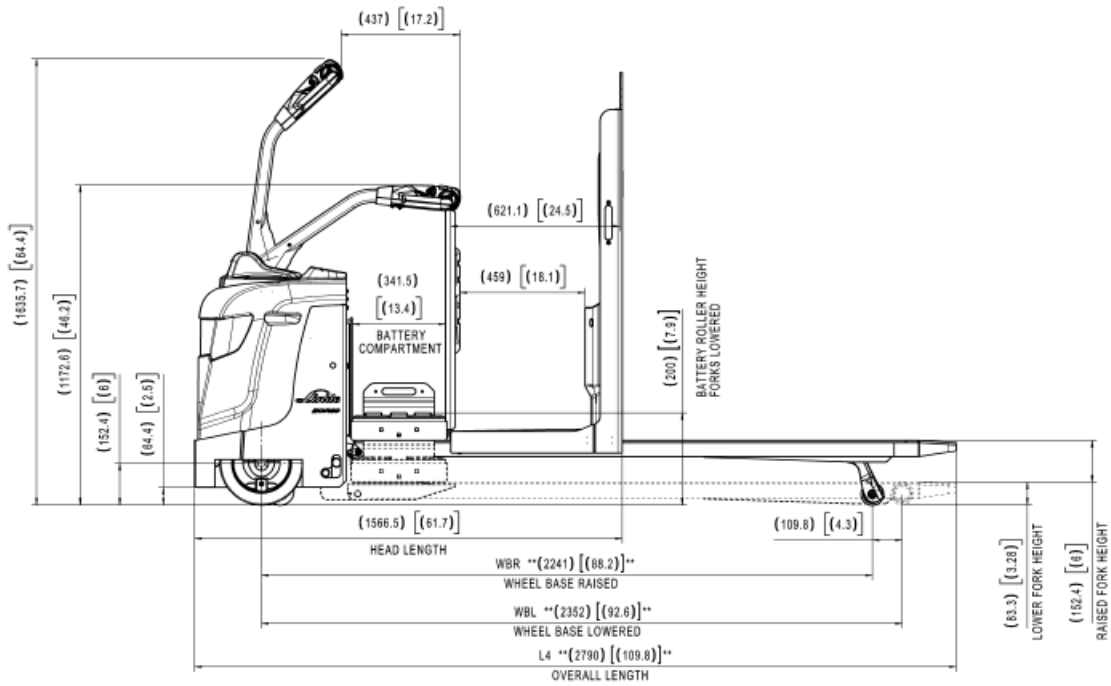

Fork Specifications				
	48" SLW		96" SLW	
	Imperial (in)	Metric (mm)	Imperial (in)	Metric (mm)
(W3) Fork Width	10	254	10	254
(W2) Overall Fork Width	28	711.2	28	711.2
(LW) Load Wheel Drop	40.58	1030.7	61.07	1551.2
(L4) Overall Length	109.84	2790	157.83	4009
(L3) Fork Length	48.15	1223	95.83	2443
(WBR) Wheel Base Raised	92.59	2241.3	113.11	2717
(WBL) Wheel Base Lowered	92.61	2352.2	113.10	2872.7
(TRR) Turning Radius Raised	98.20	2494.3	116.87	2968.5
(TRL) Turning Radius Lowered	102.56	2604.9	122.99	3124.1

*Refer to Technical Data Chart

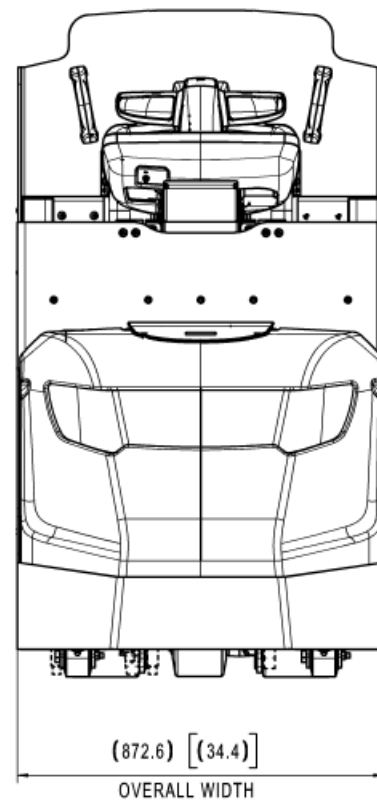
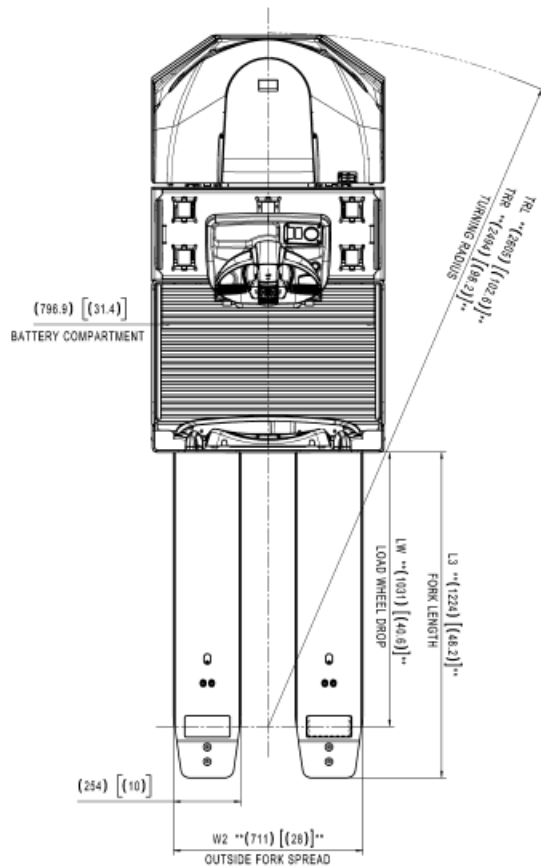
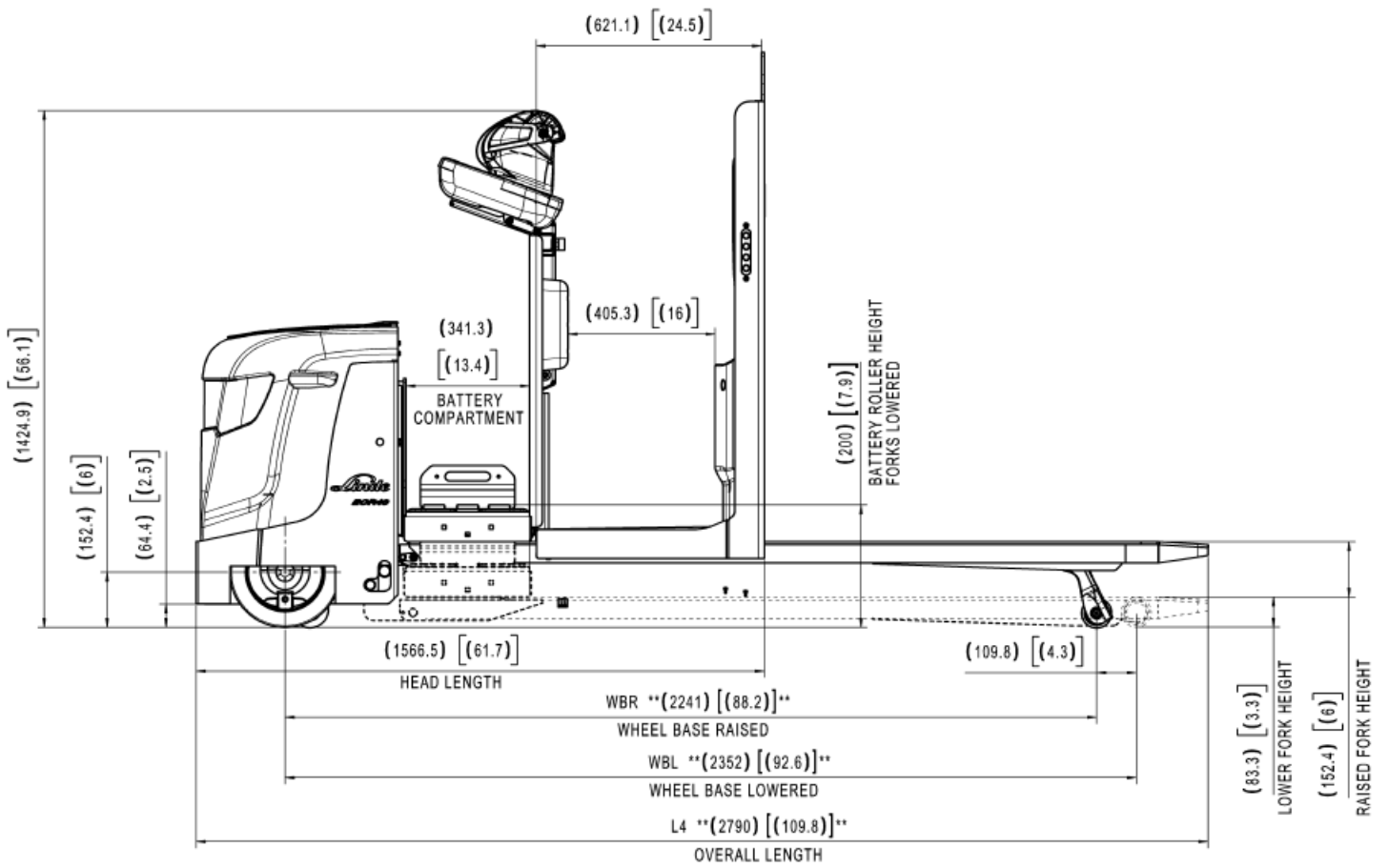

*Refer to Technical Data Chart

FEATURES

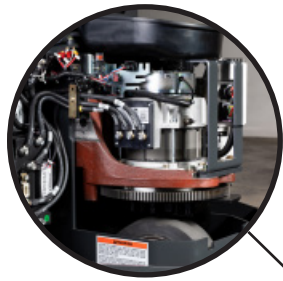

AC Drive Motor



Operator Controls



Low Step Height



One-piece Compartment Cover



Spacious Operator Compartment

Linde Series 1102 Five Features

- **Motor Compartment Cover:** The Series 1102 features a one-piece, lift off motor compartment cover. This thermosetting resin cover is a product of the latest scientific advances in the field of chemistry. In addition to its resistance to rust and corrosion, these covers offer superior impact strength, durability, and lifelong proper fit. The same rugged material is used today by most large construction machinery OEM's.
- **Operator controls:** The operator control handle features a heavy-duty cast design / steel poly construction. Soft-touch accelerator twist grips govern travel direction, speed, and also features automatic return to neutral.
- **Drive Motor:** The Series 1102 features a 24-volt, high power, AC drive motor. This high performance motor allows for maximum productivity and excellent reliability. Extended maintenance intervals for motors and complete drive systems are a direct result of this new AC technology.
- **Frame:** Truck frames feature fixed platform height and all seam-welded unitized construction. Plate steel contoured to shape for rigid strength provides maximum durability and protection for all vital components. The battery compartment is an integral part of the chassis, further adding strength to the frame.
- **Travel Control:** The AC motor controller provides exceptional flexibility by providing user tailored parameters to meet a wide variety of application requirements. The controller provides efficient use of battery voltage and has an extremely wide torque and speed range. In addition, full regeneration capability, smooth low speed control, and zero speed ramp hold applications are realized. Environmental protection is enhanced by the robust construction of the controller and the use of sealed wiring harness connectors to prevent moisture and contaminants from interrupting truck operation in all environments.

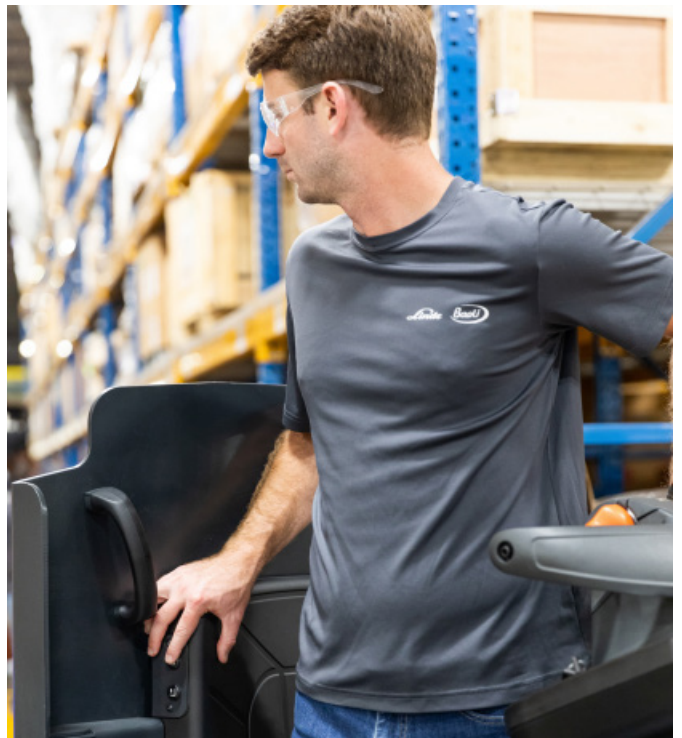

ANSI: Standard truck meets all applicable mandatory requirements of ANSI/ISO/BS5.1 standards for powered industrial trucks.
 NOTE: Performance data may vary due to motor and system efficiency tolerances. The performance depicted represents normal values obtained under typical operating conditions. Metric dimensions are in millimeters unless otherwise specified. All metric dimensions are not direct equivalents due to rounding data. The descriptions and specifications included on this data sheet were in effect at the time of printing. KION North America Corporation reserves the right to make improvements and changes in specification or design without notice and without incurring obligation. Please check with your authorized Linde dealer for information on possible updates or revisions.

For more information on Linde Material Handling equipment, please contact:

KION North America Corporation
 2450 West 5th North Street, Summerville, SC 29483
 Phone: (843) 875.8000 Truck Sales Fax: (843) 875.8471
 Email: trucksales.na@kiongroup.com
 www.kion-na.com

